

95 saturn manual transmission fluid



File Name: 95 saturn manual transmission fluid.pdf

Size: 3848 KB

Type: PDF, ePub, eBook

Category: Book

Uploaded: 24 May 2019, 12:13 PM

Rating: 4.6/5 from 769 votes.

Download Now!

Please check the box below to proceed.



I'm not a robot



reCAPTCHA
Privacy - Terms

Book Descriptions:

95 saturn manual transmission fluid



The front drivers side door was damaged and needs to I just need to know if there are The back doors do not open at all. The front doors do not open from the inside. The front windows will not roll down. Will the parts from a 1996 Saturn SL1 fit on my 1996 Sat. Does the 1993 DOHC vers. Please refer to CarGurus Terms of Use. Content will be removed if CarGurus becomes aware that it violates our policies. Is this car a manual or automatic CarGrrl Got a code of P0708 do I replaced trans range sensor.now it has a hard time shifting out of Please refer to CarGurus Terms of Use. Content will be removed if CarGurus becomes aware that it violates our policies. I believe I topped it off when i first bought it and I believe it used ATF Dexron II or III or something which I thought was odd at the time. I dont believe it has gone down since but I also think it may never have been changed. Does it need to be, and if so, how often. Or how long ago should it have, lolI couldnt find any threads for the manual because Ive heard it is done only once. Could I use a turkey baster method and put in the same amount I take out. Is there a filter associated with the manualThere is no filter for manuals. Once trained, put the bolt back in also listed in owners manual how to do as well as link in the posts above. Get a funnel with long tube and pour in new fluid. Put dipstick back in and your done. Get a Great PriceMaintenance Schedule for your Car or Truck. Doing so could save you hundreds of dollars on repairs down the road. Relevant discussion may be found on the talk page. Please help improve this article by introducing citations to additional sources.By using this site, you agree to the Terms of Use and Privacy Policy. Doublecheck your spelling or try a new search. Manual transmissions use a variety of oils regular motor oil, heavyweight hypoid gear oil or even automatic transmission fluid in some cases. Your owners manual will tell you what your transmission calls for.<http://www.timocomputer.cz/files/eos-1100d-service-manual.xml>

- 1.0.

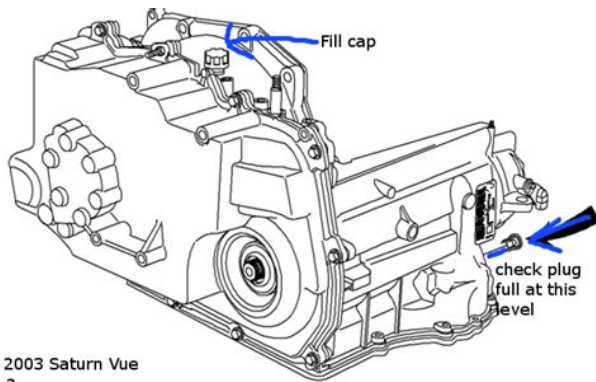

2003 Saturn Vue
7

Letting your car run low on transmission fluid can cause the transmission to shift improperly or even not at all. It also can harm the internal parts of your transmission, which will not be properly lubricated. Unfortunately, you may not hear any noises or have other clues that your transmission is low on fluid, until it's too late. Checking the transmission fluid level requires working under the hood of your car with the engine running. This can be very dangerous if you aren't careful. You should therefore contact your garage mechanic in order to have it checked. They will have equipment for checking oil levels and topping it up if necessary. If, however, you still wish to carry out this operation yourself, here is our advice. Refer to your service manual to find out what transmission fluid your gearbox requires and how frequently it should be changed. The manual will also tell you where the filling cap is located. This is where the transmission is located on most cars with rearwheel drive. On cars with frontwheel drive, the transmission dipstick is usually located in the front of the engine, connected to the transaxle. Disengage the clutch and apply the handbrake. If your car has been used for more than 30 minutes, allow the engine to rest for a few minutes so that the transmission fluid can cool down. This is important for your safety, as well as ensuring that the results are not biased. Given that there is no gauge, you may use a metal stem or screwdriver in order to probe the oil level and find out how high it is in the sump. If this happens, then it is at the right level. Quickly replace the cap. However, we recommend that you get a professional to carry this out. Remember to screw the filling cap back on in accordance with the instructions in the user manual. You may order presentation ready copies to distribute to your colleagues, customers, or clients, by visiting <http://mistlondon.com/userfiles/eos-1d-iii-manual.xml> If your transmission fluid is leaking, it can cause damage to your engine.



Manual transmissions consist of internal gears, bearings, and synchronizers that allow the driver to shift gears. Many manual transmissions are lubricated with a heavy petroleum-based oil. When this oil breaks down, its lubricating properties break down, which can make it harder for the driver to get the transmission into gear. Place the wheel chocks around the rear tires. Using the hydraulic floor jack, lift the front of the vehicle one side at a time at the manufacturer's suggested jacking points. Lift it just high enough for you to gain clearance underneath. Place the jack stands under the manufacturer's lifting points and lower the vehicle onto the jack stands. Most of the time, the filler plug is a large bolt located about halfway up the side of the transmission. Using the ratchet and the socket that fits snug on the filler plug, remove the filler plug. Check the fluid level per the

manufacturers specifications from a repair manual. If you don't, then the fluid is low. If there is fluid at that level, then no additional fluid is needed. Using the fluid pump, add fluid into the transmission through the filler plug. Reinstall the filler plug and tighten it to manufacturer's specifications. Using the floor jack, lift the vehicle one side at a time and remove the jack stand. Then lower the vehicle to the ground. However, if you are not familiar with the type of system your vehicle has or if you are not comfortable replacing the transmission fluid yourself, then you should consult the assistance of a certified mechanic, like one from YourMechanic. If you're in doubt about how frequently to check your transmission fluid, you can look up your car to find out more about when your car needs to be serviced. Get service at your home or office 7 days a week with fair and transparent pricing. Check your inbox to get started. Please consider whitelisting Autoblog.

But ads are also how we keep the garage doors open and the lights on here at Autoblog and keep our stories free for you and for everyone. And free is good, right. If you'd be so kind as to whitelist our site, we promise to keep bringing you great content. Thanks for that. And thanks for reading Autoblog. A drop down menu will appear. The exact text will differ depending on the actual application you have running. It only takes a few seconds. Please follow the instructions below to enable JavaScript in your browser. The great thing about the package is The package includes Recaro seats to So when ordering your new Cobalt SS Supercharged, make sure to select the Performance Package G85 option to get your Cobalt Quaafeequipped. You can order one from me under part number 57.309.180 Summary shown below It features higher torque carrying capacity than many Both cable Torque transfer. Easy! See customer service page for refund and return details You can buy with confidence! Saturn manufacturers popular cars, including the SL2, and they are often spotted on the American road. Your SL2 always will be a nicely built vehicle but even the most wellprotected cars will require mechanical service and repair. The quality manufacture and high value that come with a Saturn SL2 are good reasons for usually buying performance and aftermarket systems of at least that quality; highquality parts dont always have to break the bank. When your car breaks down, the best answer is a new high performance OEM or replacement auto part to keep your Saturn in likenew shape. Often the most frustrating job about doing work on your vehicle is looking for a reliable source of quality parts. Reliable OEM parts are what mechanics need to keep that Saturn in running order however tough the conditions.

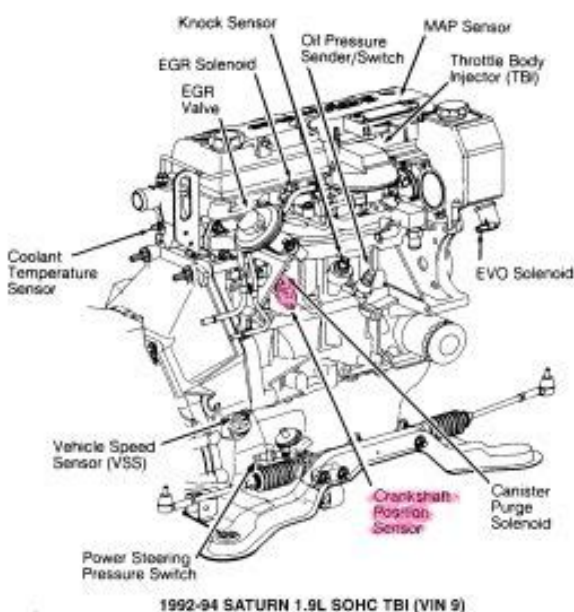

<http://www.bouwdata.net/evenement/bose-roommate-manual>

When you want to order Saturn SL2 parts, its a good strategy to shop for the finest parts on the market and at Parts Geek you always get the best prices around all handled with first-rate order fulfillment. After finding a good gear puller, the job was done in a couple hours. The service was fantastic. RAVENOL ATF BTR 95LE is an ATF Automatic transmission fluid for modern automatic transmission of BTR Engineering Australia. Guarantees maximum wear protection in all operating conditions. RAVENOL ATF BTR 95LE is red colored. Application Notes RAVENOL ATF BTR 95LE is for use in automatic transmission of BTR Engineering Australien for SsangYong Musso, Korando, Rexton, Aktyon, FORD Falcon, Fairlane, LTD, Maserati Quattroporte, 3200GT, Mitsubishi VF Nimbus, KF Verada and others. Under normal operating conditions maintenance-free filling. Not sure of the correct transmission fluid, you can ask your garage or the car dealer with respect to the original OEM gear type and number or consult our advisers. The transmission regulates the energy from the engine to the tires, providing more consistency and safety for you when you're driving. While your engine is running, your transmission gets hot. This is why engines are designed to use transmission fluid, which keeps your transmission from getting too hot and being damaged. Over time with use, your transmission fluid becomes dirty, leaving your transmission more vulnerable to damage from heat. To avoid possible costly repairs, have your transmission fluid checked regularly during your McElwain Chevrolet service appointment. Automatic transmissions automatically select the correct gear for the driving conditions without the driver having to monitor. Manual transmissions rely on the driver to select and switch gears constantly, using the clutch. Keep an eye out for the following signs, if you begin to notice any of these problems, schedule service with McElwain Chevrolet to have your vehicle inspected.

<https://comprarpegatinas.com/images/canon-lide-50-scanner-manual.pdf>



You shouldn't feel any grinding, slipping or shaking sensations as it switches gears. If you notice brown, bright red or pink puddles or leaks under your vehicle, it could be a transmission leak from a faulty gasket or seal. Have it looked at immediately. Bring your vehicle to McElwain Chevrolet as soon as possible. If you don't feel safe driving, call us and we can help arrange a tow. It may be something small that your computer has sensed and could save you money by having it checked by McElwain Chevrolet rather than waiting. We have state-of-the-art service facilities and use the latest diagnostics to maintain and repair your Chevrolet at a competitive price. At McElwain Chevrolet, we use only genuine Chevrolet parts, so you can be sure your vehicle will perform as well as the day you got it. See owner's manual for specific oil grades recommended by vehicle model. Allow 6 to 8 weeks for delivery of debit card. Excludes Chevrolet Performance engines and transmissions. All parts

MUST be GM Genuine or ACDelco parts to be eligible for this offer. Allow 6 to 8 weeks for delivery of debit card. Allow 6 to 8 weeks for delivery of debit card. See owners manual for specific oil grades recommended by vehicle model. Allow 6 to 8 weeks for delivery of debit card. Saw this on my Facebook this morning, it gave me a chuckle so I had to share. Since I was 12 years old. Valentines Day for Manual Car owners. Automatic vs Manual Transmission Constant updates of the best funny pictures and memes on the internet..if you ever teach someone to drive a stick shift Trucks Mopar Cars Trucks Cool Cars Hot Rods Muscle Cars Dream Cars Custom Cars Fast Cars Late Night Randomness 31 Photos Suburban Men Late Night Randomness is a collection of photos we have found in searching the web that doesn't necessarily fit in with our other posts or is perhaps a little too edgy to present earlier in the day. They're still cool and beautiful, so we wanted to share them with you.

<http://www.compusiteinc.com/images/canon-lide-30-manual.pdf>



How To Drive A Stick Shift The Basics How To Drive A Stick Shift The Basics You might think driving a car with a manual transmission, also known as a stick shift, is. Speaking as someone who still drives a manual transmission. Manual Transmission AntiTheft Device Poster by ApexFibers Buy Manual Transmission AntiTheft Device by ApexFibers as a ALine Dress, Acrylic Block, Art Print, Bath Mat, Throw Blanket, Canvas Mounted Print, Canvas Print, Classic TShirt, Clock, Sleeveless Top, Magnet, Drawstring Bag, Duvet Cove. Funny Quotes Quotes Wise Words Words Lyrics Me Quotes Sayings Story Of My Life Words Of Wisdom Bad bitch Pinterest Explore Log in Sign up Privacy. It appears that the page you are looking for does not exist or has been moved elsewhere. If you keep ending up here, please head back to our homepage or try the search form below. Though Saturn is the newest division of General Motors GM, some of the car's defects have been around other GM models for a long time. CAS has received complaints on common Saturn defects such as engine problems, transmission breakdowns, water leaks, and other body defects. GM tried to do everything

right with the Saturn but missed several major marks. Even Saturns with air bags still have this motorized passive belt system which induces 70% of occupants to forget to use the separate lap belt. The 1991-92 Saturns both had failing passenger crash test scores. Not until Saturn came out with a standard dual airbags in 1995 did it pass all the crash tests. An example of problem avoidance came in Saturn's largest recall of 352,883 1991-93 models for underhood fires caused by a short circuit in the generator which led to excess current and overheating in the wiring harness as well as generator failure. Rather than replace the defective and more expensive generators, Saturn opted to change the wiring from the generator to tolerate the higher current from the short circuit leaving the owner to pay for any generator that failed.

Service bulletins issued by Saturn document dozens of problems, including engine, transaxle, and other components. Manual transaxles may pop out of fifth gear, and automatics have a harsh or erratic upshift. On SC models, using the horn can cause the headlights to pop up. The engine can miss, surge, backfire, lack power on acceleration, or stall after startup. Saturn notified about 1,800 owners of 1991 models that their engines had incorrect coolant supplied by Texaco and that they would get new cars. Engine problems continue to plague Saturn with 1991-97 models needing new cylinder heads due to coolant mixing with the oil. Your information will help us build a strong case against GM as we fight for action on Saturn defects. Your contribution is tax deductible which entitles you to our quarterly newsletter, Lemon Times. Please submit the membership form along with your contribution and complaint. MAJOR RECALLS Copies of recalls may be obtained by calling NHTSA's Technical Reference Division at 202-366-2768. Theme ColorMag by ThemeGrill. Powered by WordPress. The transmission regulates the energy from the engine to the tires, providing more consistency and safety for you when you're driving. While your engine is running, your transmission gets hot. This is why engines are designed to use transmission fluid, which keeps your transmission from getting too hot and being damaged. Over time with use, your transmission fluid becomes dirty, leaving your transmission more vulnerable to damage from heat. To avoid possible costly repairs, have your transmission fluid checked regularly during your Fellers Chevrolet service appointment. Automatic transmissions automatically select the correct gear for the driving conditions without the driver having to monitor. Manual transmissions rely on the driver to select and switch gears constantly, using the clutch.

drmarlenebothma.co.za/wp-content/plugins/formcraft/file-upload/server/content/files/1627ee528970ab---brother-pt-1090-manual.pdf

Keep an eye out for the following signs, if you begin to notice any of these problems, schedule service with Fellers Chevrolet to have your vehicle inspected. You shouldn't feel any grinding, slipping or shaking sensations as it switches gears. If you notice brown, bright red or pink puddles or leaks under your vehicle, it could be a transmission leak from a faulty gasket or seal. Have it looked at immediately. Bring your vehicle to Fellers Chevrolet as soon as possible. If you don't feel safe driving, call us and we can help arrange a tow. It may be something small that your computer has sensed and could save you money by having it checked by Fellers Chevrolet rather than waiting. Set toe in, camber and caster where applicable. Check tie rods and ball joints. Check tire pressure and inspect tires for cuts, damage, and uneven wear. Plus tax, if applicable. Coupon valid at vehicle check-in. Plus tax, if applicable. Not valid with other offers. Present offer at time of service. No cost installation with purchase. Plus tax, if applicable. Not valid with other offers. Present offer at time of service. Includes mounting, balancing and disposal of old tires. Some restrictions may apply. Plus tax, if applicable. Not valid with other offers. Present offer at time of service. Set toe in, camber and caster where applicable. Check tie rods and ball joints. Check tire pressure and inspect tires for cuts, damage, and uneven wear. Plus tax, if applicable. Coupon valid at vehicle check-in. This exclusive offer not valid for insurance work, warranty, other offers or service specials. Plus tax, if applicable. Present offer at time of service. Allow 6 to 8 weeks for delivery of debit card. See owner's manual for

specific oil grades recommended by vehicle model. See owners manual for specific oil grades recommended by vehicle model. Excludes Chevrolet Performance engines and transmissions. All parts MUST be GM Genuine or ACDelco parts to be eligible for this offer.

cnccat.com/products_img/files/canon-mp500-owners-manual.pdf

Allow 6 to 8 weeks for delivery of debit card.Allow 6 to 8 weeks for delivery of debit card.Allow 6 to 8 weeks for delivery of debit card.

<http://fscl.ru/content/bose-roommate-manual>